

Specialized LC + Crystal Filters



NIC manufactures specialized LC and Crystal filters with a variety of unique customizations to meet the complex requirements of the advanced systems used in today's Military, Space and Commercial markets. Years of engineering, design experience and production techniques have given NIC the ability to develop unique high performance solutions that off the shelf designs cannot satisfy.

Delay, Phase & Amplitude Equalization

Unique Transfer functions

 Elliptical or Pole Placed designs

 Gaussian

 Bessel

Delay, Amplitude or Phase Matching

Notch & High Power Filters

Space Qualified Products



Delay, Phase + Amplitude Equalization

Specialized LC + Crystal Filters



- LC Designs - DC to 6000 MHz
- Crystal Bandpass Designs - DC to 250 MHz
- Compact Size and High Selectivity
- Very Low GDV in Passband

Crystal Filter: Delay Equalized: 10:1

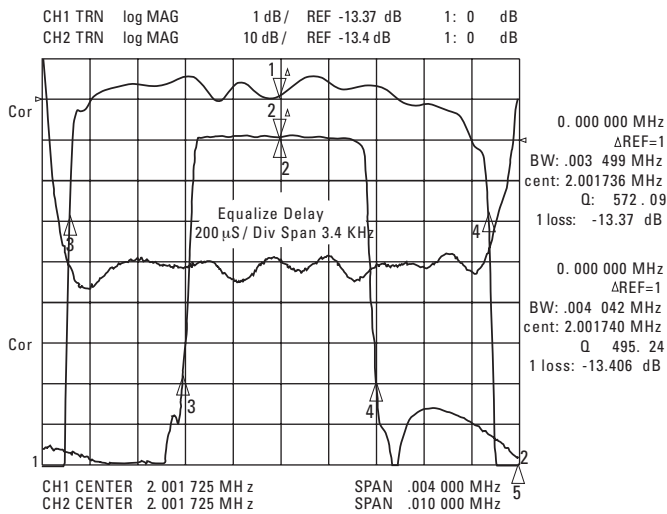

Equalized LC and Crystal Filters provide solutions to help maintain high selectivity while achieving flat group delay or linear phase. By combining traditional filter topologies and special equalizing sections, NIC provides unique solutions for today's demanding applications.

LC Filter: Delay Equalized

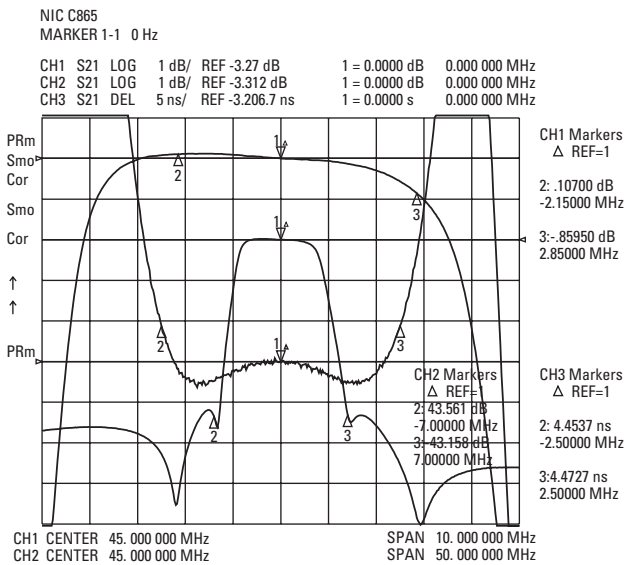

Contact factory with your specific requirements. For screening capabilities, refer to page 3.

For common package outlines, refer to LC & Crystal sections.

Unique Transfer Functions

Specialized LC + Crystal Filters

- All Tranform Types and Transfer Functions
- LC Designs - DC to 6000 MHz
- Crystal Bandpass Designs - DC to 250 MHz
- Very Low Phase Noise

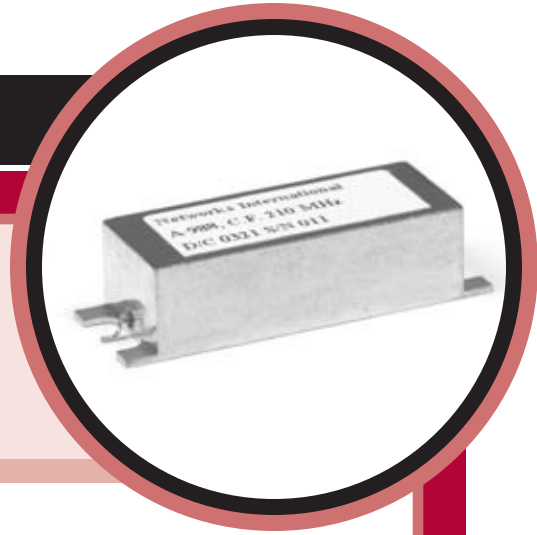

NIC designs and manufactures all filter transfer functions for both LC and Crystal filters. We leverage our 100+ years of RF design experience to develop high performance solutions that off the shelf designs cannot satisfy.

Gaussian

Gaussian to 6 dB

Gaussian to 12 dB

Bessel

Sin X/X

ERP .05

ERP .5

Elliptical or Pole Placed

Gaussian LC Filter

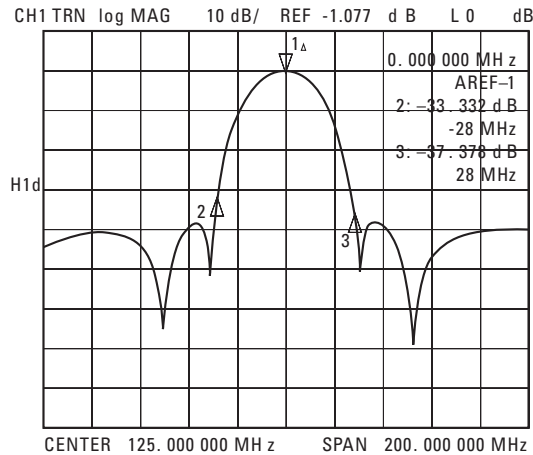

Elliptical Function Crystal Filter Shape Factor 80/1, 1.044:1

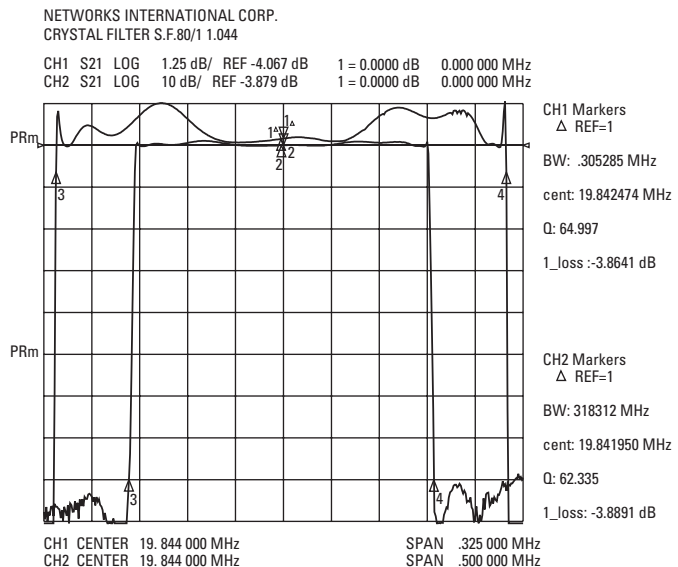

Contact factory with your specific requirements. For screening capabilities, refer to page 3.

For common package outlines, refer to LC & Crystal sections.

Delay, Amplitude or Phase Matching

Specialized LC + Crystal Filters

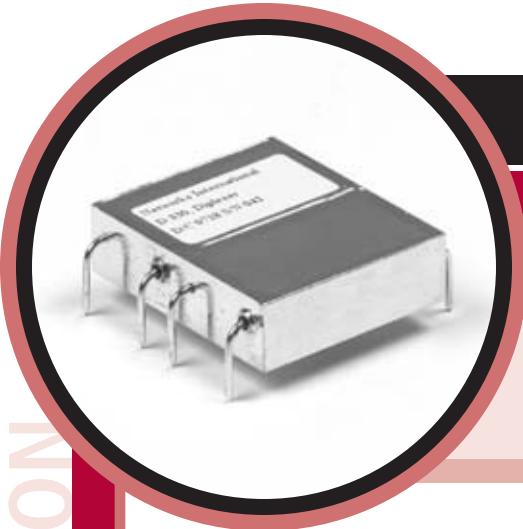

- LC Designs - DC to 6000 MHz
- Crystal Bandpass Designs - DC to 250 MHz
- Delay Matching $< \pm 1$ nS
- Amplitude Matching $< \pm 0.2$ dB
- Phase Matching $< \pm 0.5^\circ$

Quad Set: Phase vs. Amplitude

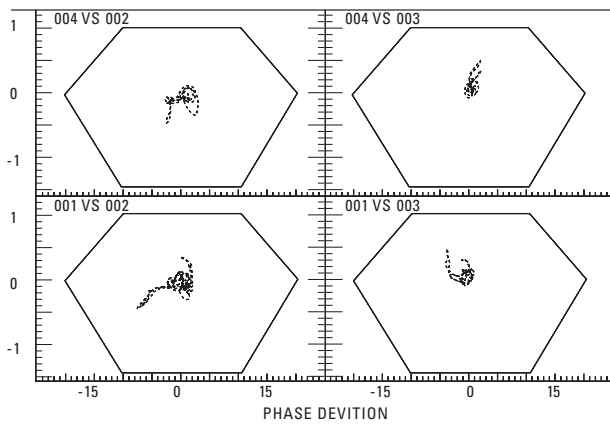

Matching filter performance characteristics play an important role in many of today's demanding applications. NIC's proven "design to match" filter characteristics provides performance capabilities that are unsurpassed. Matching one-to-all, pairs, tri-sets or up to seven filters to perform in all types of environmental conditions is a unique capability that NIC has perfected through years of experience.

Phase Matched Pair $< 0.5^\circ$ over Filter Passband

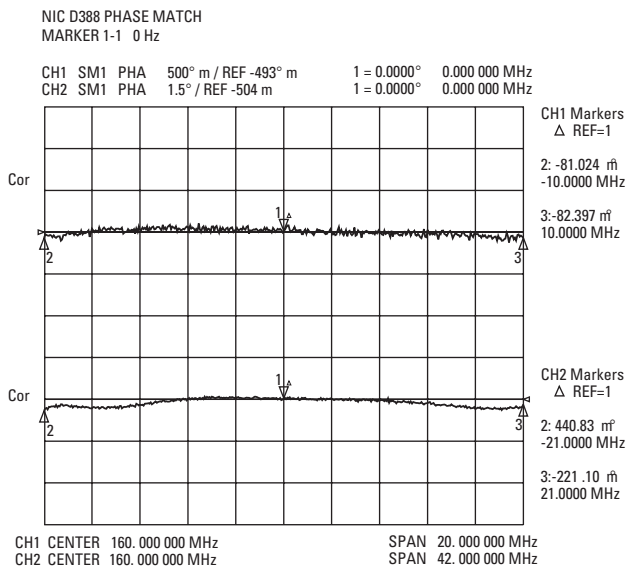

Contact factory with your specific requirements. For screening capabilities, refer to page 3.

For common package outlines, refer to LC & Crystal sections.

Band Reject Filters

Specialized LC + Crystal Filters

- LC Designs - DC to 6000 MHz
- Crystal Bandpass Designs - DC to 250 MHz
- Low Passband Loss, High Notch Rejection

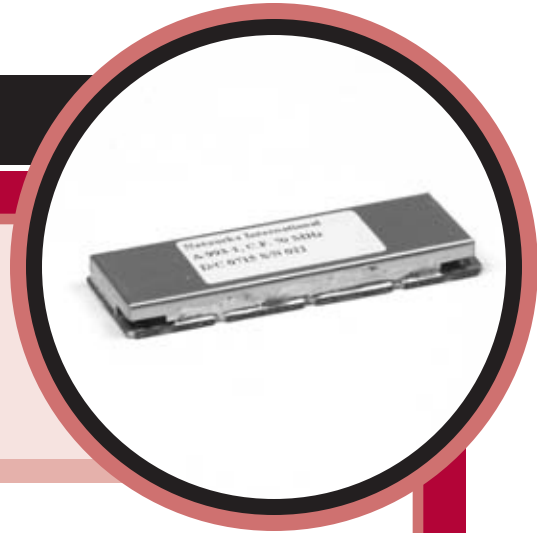

Band Reject Filters

NIC manufactures both Crystal and LC Notch or Band Reject filters for Military, Space and Commercial applications. These filters are designed to meet very narrow or wide passband or stopband requirements.

Crystal Band Reject Filter

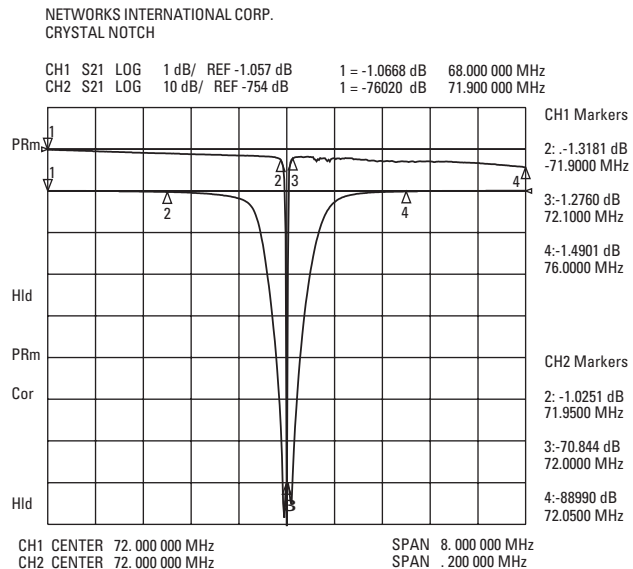

High Power Filters

NIC manufactures products with the ability to handle higher levels of RF energy while maintaining their specified electrical requirements. The main advantage of NIC's higher power Crystal and LC filters is their compact profile, low-loss, excellent VSWR and minimum heat build-up.

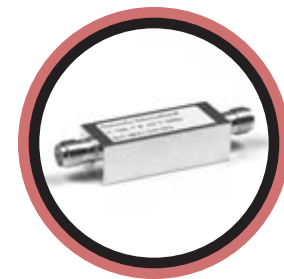

LC Designs - DC to 6000 MHz

Up to 50 W Operating, 250 W without damage

Crystal Bandpass Designs - DC to 250 MHz

Up to +30 dBm Operating (1 Watt)

Contact factory with your specific requirements. For screening capabilities, refer to page 3.

For common package outlines, refer to LC & Crystal sections.